

# SKIOLD DISC MILL®



**SKIOLD MAKES  
THE DIFFERENCE!**



- Optimal feed structure for all animal groups
- Exceptional durability on wearing parts
- Low power consumption
- Capacity up to 12 t/h
- Quiet running

# SKIOLD DISC MILL®



## NEW TECHNOLOGY, NEW ADVANTAGES

The SKIOLD disc mill® is the result of several years of product development and testing. The object was to develop an all-round mill for grinding of grain and crops; and that with low power consumption, quiet running and minimum dust levels. At the same time the mill should allow automatic adjusting of the grinding degree during operation according to the required fineness and structure of the specific feed mixtures for different animal groups or species. Also it was the object to develop a compact mill that fits in easily, even in existing plants. The grinding takes place between two discs consisting of a number of segments produced in tungsten carbide. This is the same material as is used for producing cutting tools in the engineering industry. Thus, quality- and product-wise, the SKIOLD disc mill® meets all the demands made by today's largest and most professional animal producers as well as commercial feed millers.

## HIGH CAPACITY, LOW POWER CONSUMPTION

The mill is available in three sizes: The SK2500 with a 5.5 kW or a 7.5 kW electric motor; the SK5000 with a 15 kW or a 22 kW electric motor and the SK10T with a 55 kW electric motor. When grinding wheat, the capacity varies from 1,000 to 12,000 kg/h, depending on mill size and grinding degree, giving a typical power consumption of only 5 kWh per ground tonne. The motor is mounted directly on the running disc, securing the entire motor power to be used in the grinding process. The capacity varies according to the different raw materials and the required grinding degree - for further information please see diagram on the back of the leaflet.



## EXCEPTIONAL DURABILITY ON WEARING PARTS

The grinding takes place in two steps. First the raw materials are coarsely ground between two inlet rings before the final grinding between the grinding discs. The discs consist of a number of segments with the hardness of 1,700 HV, whereas the hardness of the hammers in a traditional mill is just 600 HV after hardening. When grinding normal, cleaned grain, the durability of one set of discs in the smallest mill will be up to 5,000 tonnes, 10,000 tonnes in the medium size mill and up to 20,000 tonnes in the largest model which considerably increases service intervals of the mill.

# SKIOLD DISC MILL®



## FEED STRUCTURE

The ideal feed structure is not the same for all species of animals and groups within the same species just as the grinding process is different for different types of raw materials. Therefore it is important to be able to change the grinding degree during operation and between the different feed mixtures in order to get the optimal structure of the prepared feed. The distance between the two grinding discs determines the grinding degree and the disc mill® is constructed with stepless change of the distance between the discs. The distance can be changed manually by means of a handle on the front of the disc mill® or automatically via an actuator receiving settings from the control system of the plant.

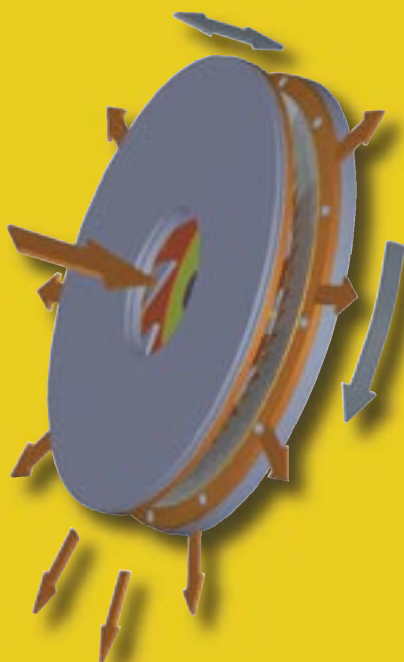

## BUILDING-IN AND USE

By virtue of its compact appearance the disc mill® fits in easily in both new and existing plants. Typically, augers are used for conveying raw materials to the disc mill®. Using frequency control for the augers, the optimal utilization of the mill capacity is secured. An auger or other conveyors can be mounted directly at the mill outlet for conveying the ground material to mixer or silo(s). If the raw materials contain many impurities, it is recommended that the raw materials are cleaned prior to grinding using a screen cleaner, as the impurities increase the wear of the mill. Again SKIOLD is fully equipped to supply effective screen cleaners which separate both sand and larger impurities from the raw materials. As standard the mill inlet is equipped with a strong pipe magnet. The disc mill® is ideal for all common types of plants, e.g. as pre-grinder of raw materials and as grinding unit in continuous or batch based feed mills. The mill has been tested and found suitable for grinding of many different raw materials including pellets with diameters up to 12 mm.

## LOW DUST AND NOISE LEVEL

The mill operates without air ventilation, which eliminates dust emission. Augers, elevators or other types of mechanical conveyors are used for conveying to and from the mill which of course SKIOLD is fully equipped to supply. The noise level of the mill is only 80 dB(A) which will be perceived by users as quiet running when compared to a traditional hammer mill having a noise level between 85 - 90 dB(A).

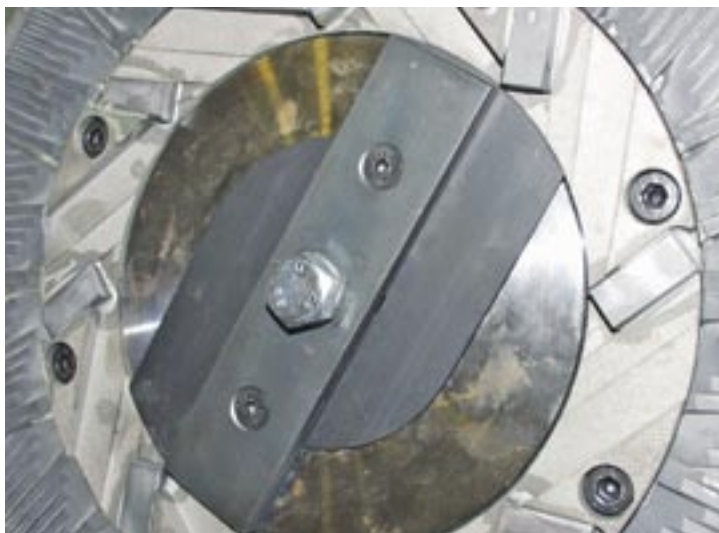

# TECHNICAL DATA

SK2500 & 5000

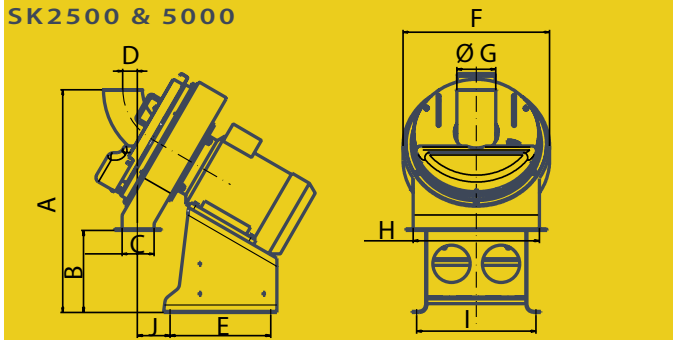

SK10T

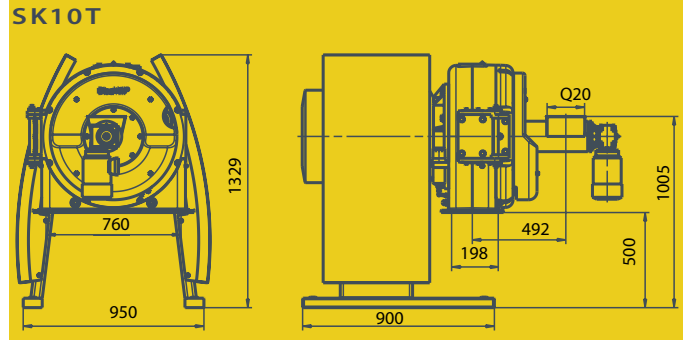

	A	B	C	D	E	F	G	H	I	J	Motor rpm	Weight kg	Noise dB	Disc diam.
SK2500 5.5 kW	629/779	227	87	60,5	215	392	100/150	300	410	123	2800	155	80	Ø300
SK2500 7.5 kW	629	227	87	60,5	215	392	100	300	410	123	2800	161	80	Ø300
SK5000 15 kW	884	325	101	58	400	582	150	482	482	130	2800	313	80	Ø455
SK5000 22 kW	894	335	101	58	400	582	150	482	482	126	2800	368	80	Ø455
SK10T 55 kW	1005	500	198	492	900	760	Q20	715	950	31	2800	1400	80	Ø550

ATEX Classification: Zone 22

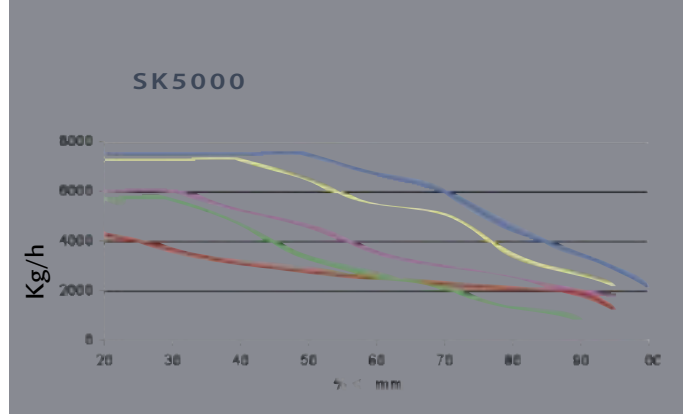
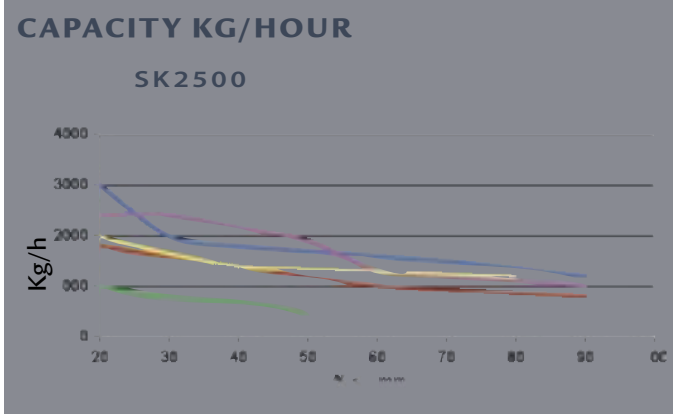

**MAIZE** Capacity depends on raw material quality, moisture content, and grinding fineness. The indicated capacities were measured in cleaned raw materials with a moisture content of 13-14%.

**WHEAT**

**BARLEY**

**OATS**

**PEAS**

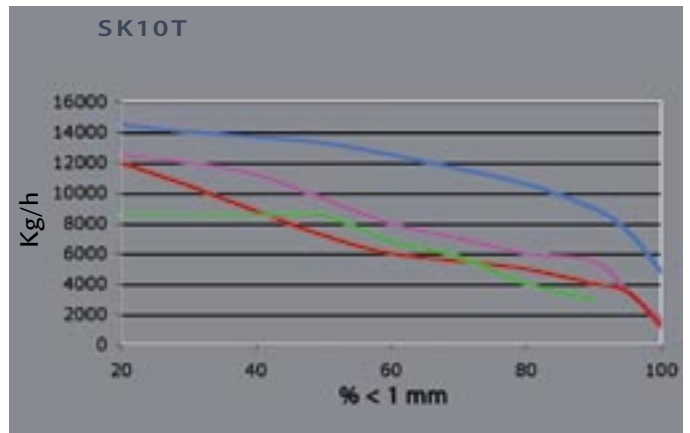

SKIOLD Reklame & Marketing - GB-2005.05.02 - All Rights Reserved.



**SKIOLDA/S**  
 Kjeldgaardsvej 3  
 DK-9300 Sæby · Denmark  
 Tel: +45 99 89 88 87  
 Fax: +45 99 89 88 77  
[www.skiold.com](http://www.skiold.com) · [skiold@skiold.com](mailto:skiold@skiold.com)



**Vacuum & Milling Solutions**  
 PO Box 869  
 Jimboomba Qld 4280 . Australia  
 Ph: 0417 447 952  
 Fax: 0755 477 677  
 Email: [martin@vacmillsolutions.com.au](mailto:martin@vacmillsolutions.com.au)  
[www.vacmillsolutions.com.au](http://www.vacmillsolutions.com.au)