

# SKIOLD TANK

Heated and Insulated Tank for Liquid Products



## SKIOLD MAKES THE DIFFERENCE!



- Ideal for storage with minimum oxidation
- For both in- and outdoor installation
- Suitable for fat, oil, molasses, etc.
- Electric heating
- Foam insulated



# SKIOLD TANK

Heated and Insulated Tank for Liquid Products

## DESIGN

The tank made of mild steel has a volume of 8 m<sup>3</sup>. Efficient foam insulation with 100 mm polyurethane foam secures minimum power consumption for heating up the tank. The tank is mounted in an upright position minimizing the liquid surface which reduces the oxidation and thereby the risk of rancidification of the liquid product. The tank is equipped with a manhole for easy inspection and cleaning. The conical bottom of the tank works as a sedimentation basin and is equipped with a drain valve for complete emptying. The tank comes with 3" connections mounted in the top of the tank for filling and ventilation pipes.

## HEATING

The selected temperature in the tank is maintained by a water heating system which emits its heat to the surrounding liquid. This indirect heating is very gentle and it prevents damage to the nutritive value of the liquid due to too high temperature. The heating system is equipped with a built-in expansion box. The heating element is a thermostatically controlled 7.5 kW electric heater. The temperature is read on the thermometer placed on the side of the tank. The heating system has a 3/4" outlet for hot wa-

ter, which can be used for heating the pipeline from the tank to the mixer. In that case, the hot water pipeline must be equipped with a circulation pump. Alternatively, the pipeline can be heated by an electrically heated cable. In both cases, the pipeline must be insulated subsequently.

## PUMP

The dosing pump is built into an integrated box in the insulated tank and is thereby protected against coldness. In addition, the durable pump is equipped with a strainer mounted

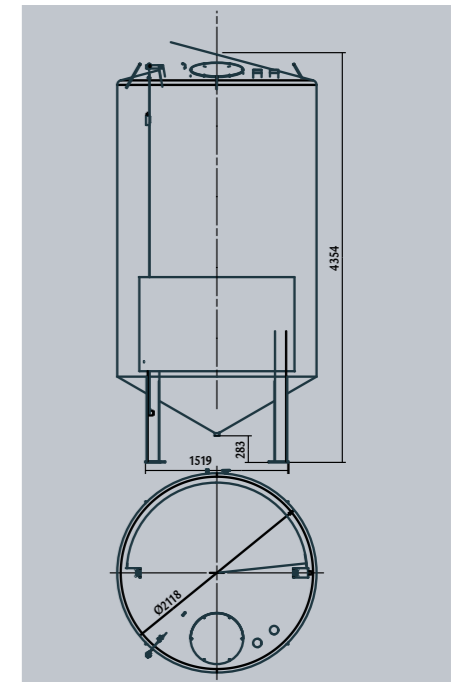

SKIOLDA/S  
Kjeldgaardsvej 3  
DK-9300 Sæby · Denmark  
Tel: +45 99 89 88 87  
Fax: +45 99 89 88 77  
www.skiold.com · skiold@skiold.com



Vacuum & Milling Solutions  
PO Box 869  
Jimboomba Qld 4280 . Australia  
Ph: 0417 447 952  
Fax: 0755 477 677  
Email: martin@vacmillsolutions.com.au  
www.vacmillsolutions.com.au

# SKIOLD TANK

Heated and Insulated Tank for Liquid Products



## SKIOLD MAKES THE DIFFERENCE!



- Ideal for storage with minimum oxidation
- For both in- and outdoor installation
- Suitable for fat, oil, molasses, etc.
- Electric heating
- Foam insulated



# SKIOLD TANK

Heated and Insulated Tank for Liquid Products

## DESIGN

The tank made of mild steel has a volume of 8 m<sup>3</sup>. Efficient foam insulation with 100 mm polyurethane foam secures minimum power consumption for heating up the tank. The tank is mounted in an upright position minimizing the liquid surface which reduces the oxidation and thereby the risk of rancidification of the liquid product. The tank is equipped with a manhole for easy inspection and cleaning. The conical bottom of the tank works as a sedimentation basin and is equipped with a drain valve for complete emptying. The tank comes with 3" connections mounted in the top of the tank for filling and ventilation pipes.

## HEATING

The selected temperature in the tank is maintained by a water heating system which emits its heat to the surrounding liquid. This indirect heating is very gentle and it prevents damage to the nutritive value of the liquid due to too high temperature. The heating system is equipped with a built-in expansion box. The heating element is a thermostatically controlled 7.5 kW electric heater. The temperature is read on the thermometer placed on the side of the tank. The heating system has a 3/4" outlet for hot wa-

ter, which can be used for heating the pipeline from the tank to the mixer. In that case, the hot water pipeline must be equipped with a circulation pump. Alternatively, the pipeline can be heated by an electrically heated cable. In both cases, the pipeline must be insulated subsequently.

## PUMP

The dosing pump is built into an integrated box in the insulated tank and is thereby protected against coldness. In addition, the durable pump is equipped with a strainer mounted

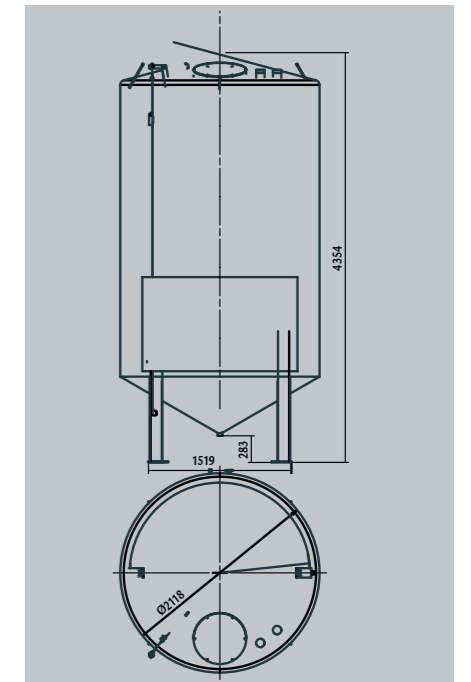

SKIOLDA/S  
Kjeldgaardsvej 3  
DK-9300 Sæby · Denmark  
Tel: +45 99 89 88 87  
Fax: +45 99 89 88 77  
www.skiold.com · skiold@skiold.com



Vacuum & Milling Solutions  
PO Box 869  
Jimboomba Qld 4280 . Australia  
Ph: 0417 447 952  
Fax: 0755 477 677  
Email: martin@vacmillsolutions.com.au  
www.vacmillsolutions.com.au